

This operator manual has information for the following RC model along with some options and accessories. Some illustrations and information may not apply to your truck.

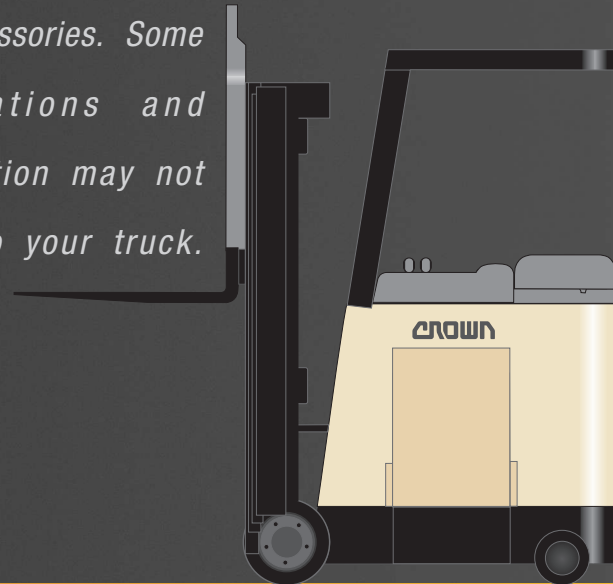

The most important component is you.

WARNING

It's the law, you must be trained and certified to operate this truck. (OSHA § 1910.178, Rev. 1999)

You or others around you can be seriously injured or even killed if you don't use this truck correctly.

Read and obey all warnings and instructions in this Manual* and on the truck.

Head, arms, hands, legs or feet outside the operator area can be pinned or crushed whenever the truck is moving. Stay within the operator area and **stop the truck completely before getting off.**

However, tipovers and falls from docks can cause serious injury or even death. **Immediately exit and move away from the truck in these emergencies.**

You can be trapped or crushed by driving the operator area under racks or other objects. **Look where you are going.**

Inspect your truck before starting work, make sure it is in good working order.

* Additional copies of this Operator Manual and all Truck Labels can be obtained from Crown Equipment Corporation, New Bremen, Ohio 45869 U.S.A.

All rights reserved under International
and Pan American copyright conventions
Copyright 1996 Crown Equipment Corp.

You Must be Certified



IT'S THE LAW, YOU MUST BE TRAINED AND CERTIFIED

Federal law states that only properly trained operators are permitted to operate a powered industrial truck and that your employer must train you and certify that you are qualified to operate this powered industrial truck. (OSHA §1910.178, Rev. 1999)

Do not operate this truck in your work place until you have been certified by your employer.

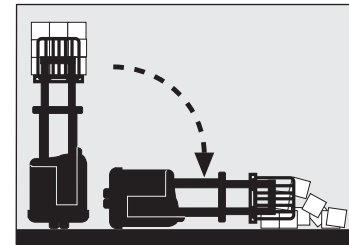

You could be killed or seriously injured if you are not adequately trained for lift truck operation!

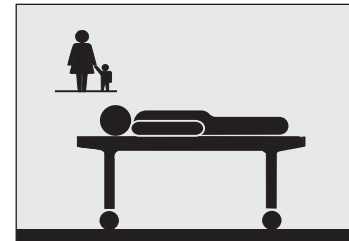

Protect Yourself

! Know the Hazards



DRIVE CAREFULLY

- Keep your hands on the controls and feet on the pedals. Keep your entire body in the operator area.
- Never stick a foot or any part of your body outside the operator area, no matter how slow the truck is moving. You cannot stop 3630 kg (8000 pounds) with any part of your body. A foot or hand caught between the truck and a fixed object will be crushed or even cut off.
- Stay away from the edge of docks and ramps. Make sure dockboards are secure. Check that trailer wheels are chocked. You could be seriously injured or even killed in a fall from a dock or dockboard.
- Keep your truck under control at all times. Drive at a speed that allows you to stop safely. Be even more careful on slippery or uneven surfaces. Do not drive over objects on the floor.

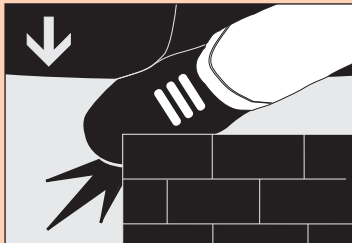

LOOK WHERE YOU'RE DRIVING

- Always be alert to the area around you and watch where you are driving. You could be pinned or crushed by objects intruding or poking into the operator area.



! Know the Hazards



AVOID FALLS AND TIPOVERS

Falls from docks and tipovers are very serious accidents; you can be crushed or even killed. Immediately exit and move away from the truck in these emergencies.

Note: This is not like sit-down rider trucks, where it is recommended that the operator stay with the truck. The best way to prevent injury is to know where you are at all times and follow the rules of safe truck operation.

- Be extremely careful when working around docks, dockboards and trailers.
- Use forward tilt only when you have the load over a stack or close to the floor.
- Travel with the load or forks close to the ground and tilted back. Watch for overhead obstructions. Perform all truck movements smoothly and at a speed that will give you time to react in an emergency.
- An unloaded truck can tip over also. Be just as careful using an unloaded truck as you are using a loaded one.



USE YOUR TRUCK SAFELY

- Keep your hands and feet away from all moving parts such as masts, chains, forks or wheels. Make sure the overhead guard and load backrest are in place.
- Never stand on or under the forks, or allow anyone else to stand on or under them. The only way to lift people is with an approved platform. Never allow passengers on the truck. There is no safe place for them.
- Before you leave your truck:
 - Come to a complete stop and lower forks to the floor.
 - Shut the truck off with the key or power disconnect.



Contents

What's in it for You?

Warning	1
You Must be Trained	2
Protect Yourself	3
Contents	5
What's in it for You?	6
Your Stand-Up Rider	7
Lift Truck Parts	9
Capacity & Load Center	11
Capacity Plate	13
Power On & Off	15
Foot Brake	17
Traveling & Plugging	19
Steering & Travel	21
Two Types of Steering	23
Fork Function	25
Retractable Guard <small>optional</small>	27
Hydraulic Accessories	28
Daily Safety Check	29
Be a Safe Driver	31
Battery Maintenance	35
Warning Labels	38

WHAT'S IN IT FOR YOU?

The better you understand your truck and how to use it, the better and safer operator you can be. Here are some guides to using this manual.

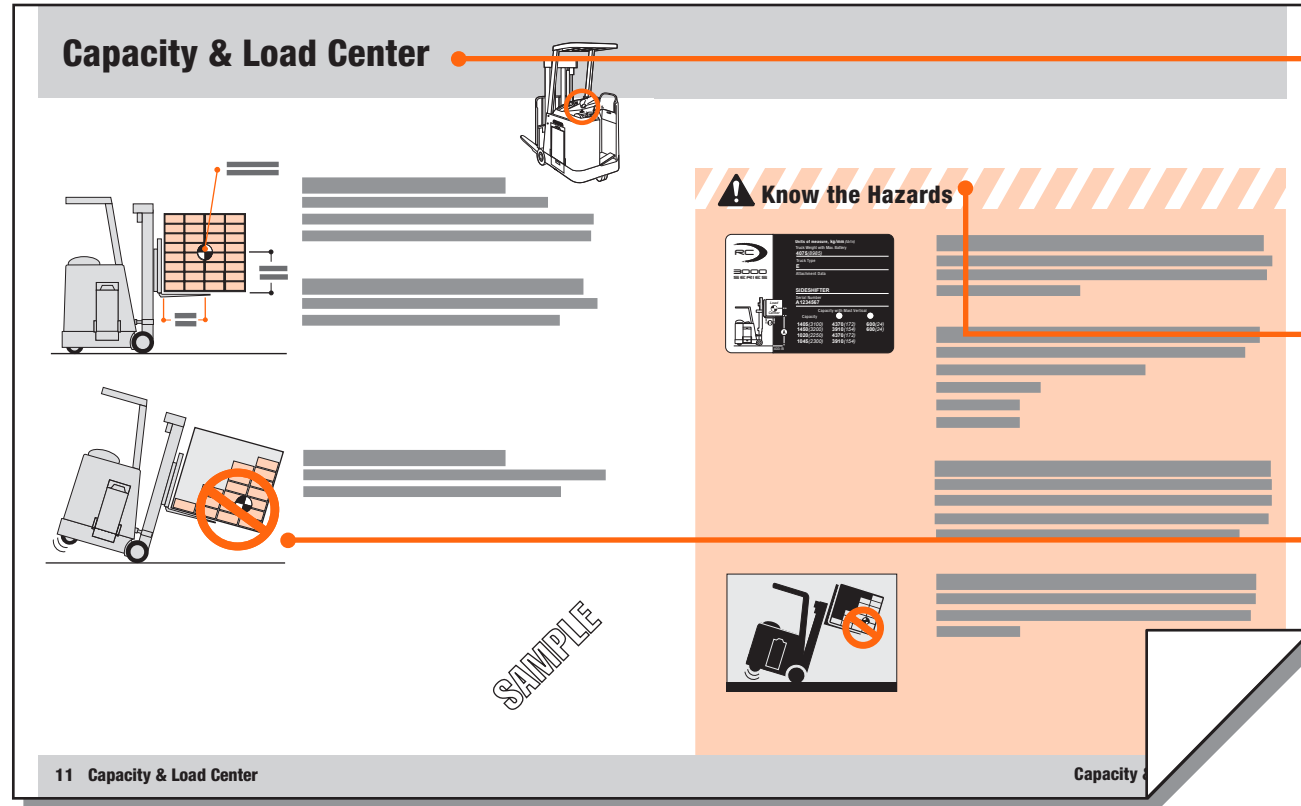

QUICK LOCATORS

In addition to the "Contents" page you can use page headings to find topics. Some pages also have a picture of the truck in the corner showing features or functions covered on that page.

"KNOW THE HAZARDS"

Watch for and read these special blocks. You will find information about possible safety hazards and how to avoid them.

HOW-TO-DRAWINGS

On many pages you will find pictures as well as text to help you understand how to use your truck safely and productively.

Your Stand-Up Rider

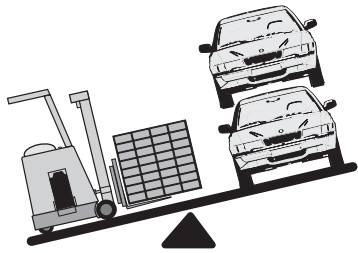

STAND-UP RIDERS

Your stand-up rider truck lifts, moves and stacks loads. It is designed for maneuverability in warehouses built with narrower aisles.

YOUR LIFT TRUCK IS NOT AN AUTOMOBILE

With a load it may weigh as much as 3 automobiles.

- You don't steer the same.
- You don't brake the same.
- You don't accelerate the same.

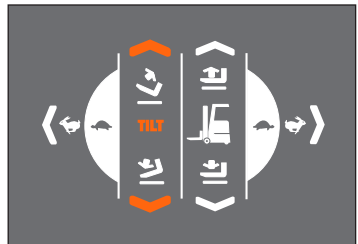

FORK FUNCTIONS, STANDARD AND OPTIONAL

Standard fork or hydraulic functions are: Raising and Lowering the forks plus Tilting the mast. Included may also be accessories like Sideshift, Carton Clamp, or Push-Pull. Your company has decided which features are needed in your work area and should train you how to use them.

HOW TO DRIVE YOUR TRUCK

Your truck is designed with a tilted floorboard and padding in the operator area. You drive your truck by standing sideways and leaning back against the pad. This, along with your hands on the controls and feet on the pedals, gives you both comfort and stability. Plus you can see and travel in either direction by turning your head.

GIVE YOUR BODY A BREAK

Take advantage of stop time. Get off the truck and flex your arms and legs. Staying alert will help you be a better and safer driver.

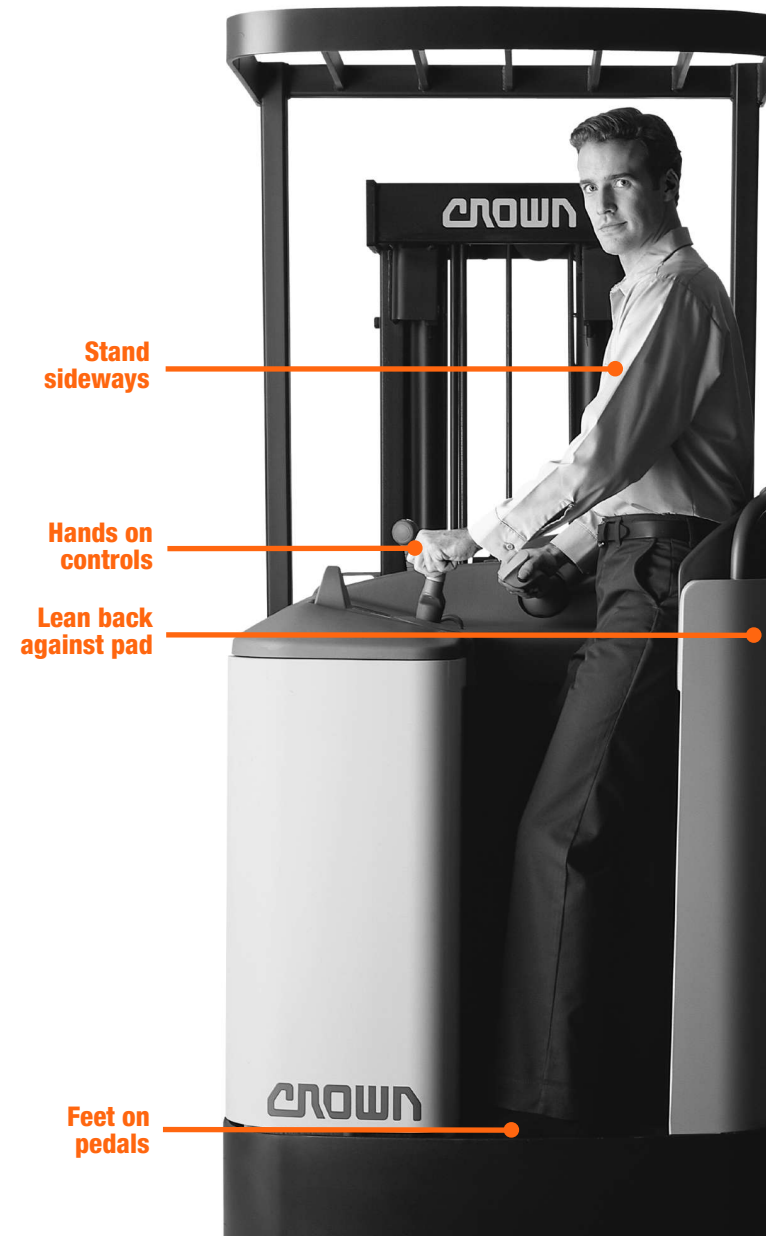

BUILT TO STANDARDS

This truck was designed and built to current industry and government standards and guidelines. For more information see the following:

- American National Standards (ASME) B56.1
- Occupational Safety and Health Act (OSHA) §1910.178, Rev. 1999
- Underwriters Laboratory (UL) 583
- National Fire Prevention Association (NFPA) 505

Lift Truck Parts

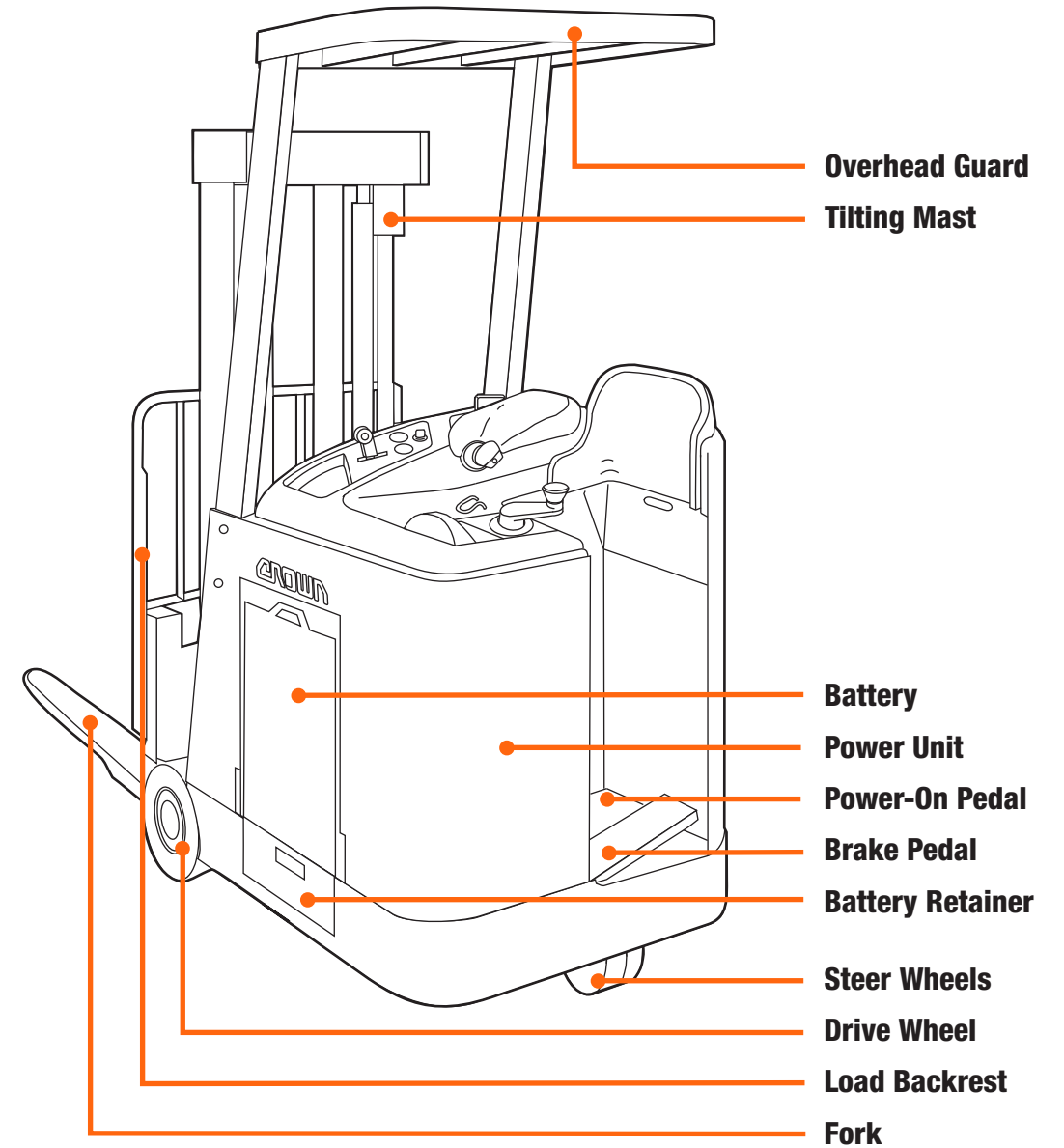
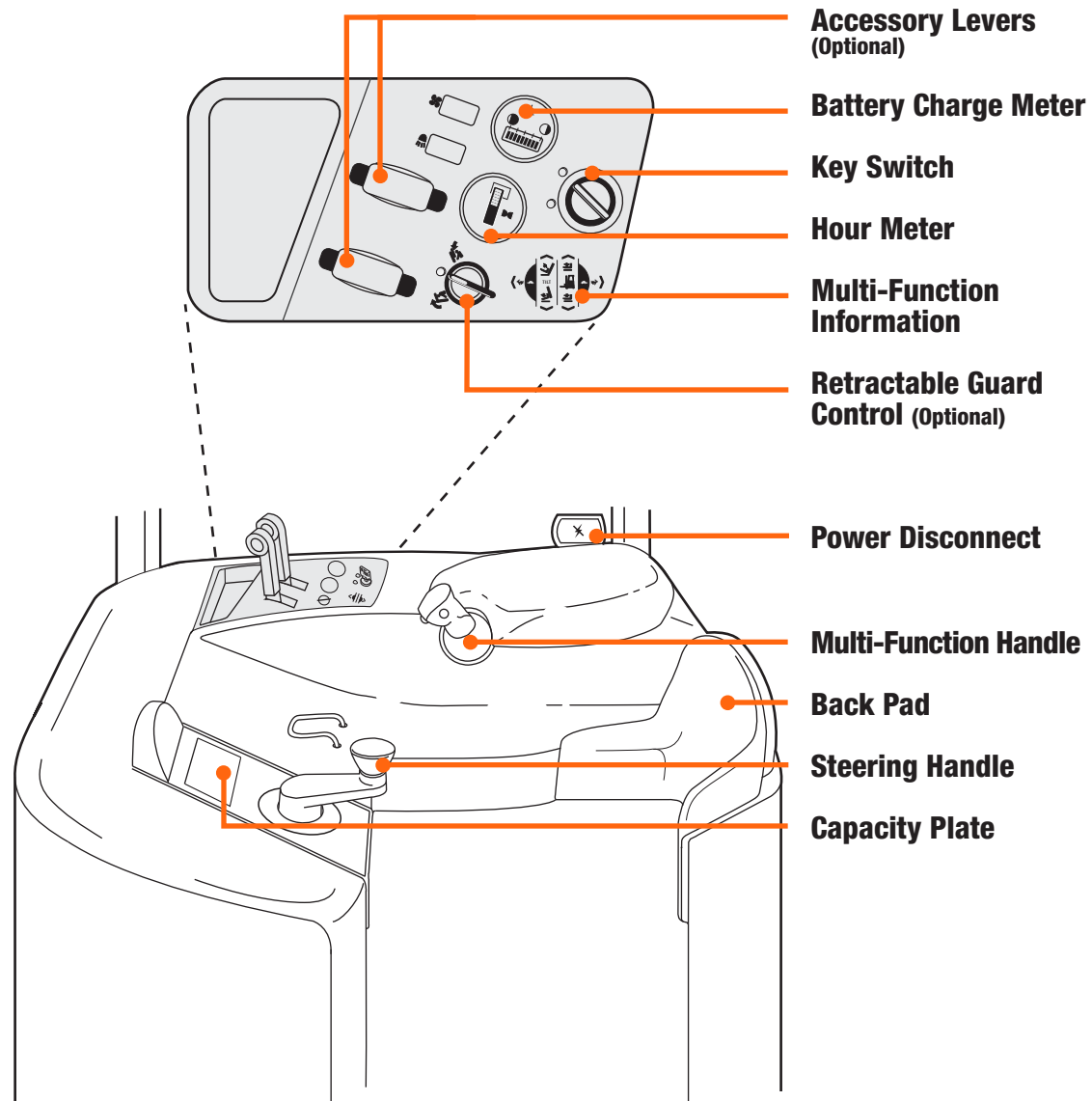

Capacity & Load Center

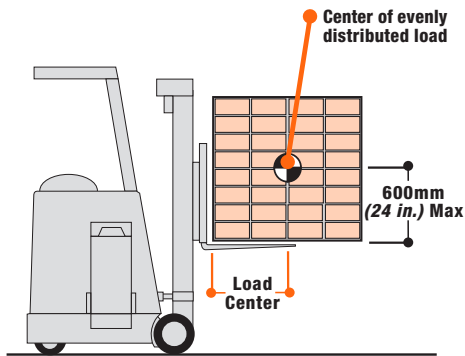
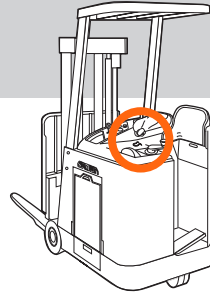

WHAT IS YOUR TRUCK CAPACITY?

Capacity is the load (including pallet or container) that can be lifted to a given height at a given load center. See the capacity plate on your truck. Make certain you use the correct units of measure.

WHAT IS LOAD CENTER?

Load center is the distance from the load backrest or vertical face of the fork to the center of an evenly distributed load.

LOADS MUST BE EVENLY DISTRIBUTED

Your truck could tip over, in any direction, if a load is shifted to the front or side of a pallet or container.

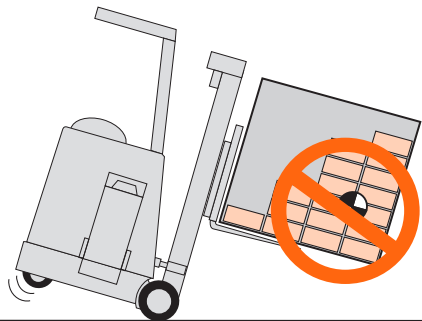

! Know the Hazards

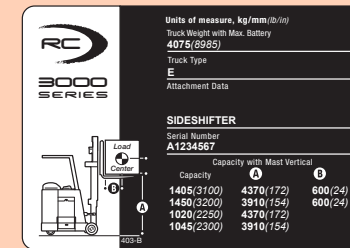

KNOW YOUR LOAD

Do not exceed the capacity shown on your truck's capacity plate. Be careful when handling long, high or wide loads. Do not handle unstable loads.

EXCEEDING TRUCK CAPACITY CAN CAUSE AN ACCIDENT

Know the capacity of your truck as shown on your capacity plate. Make certain you use the correct units of measure. Pay attention to:

- Weight of load
- Load center
- Lift height

HYDRAULIC OPERATIONS CAN AFFECT STABILITY

Capacities given on your capacity plate are for loads that are centered and level. Be extra careful when tilting a load. (This also applies to other accessories or attachments your truck may have, such as sideshift, carton clamp, push-pull, etc.)

CENTER THE LOAD

Your truck could tip over if a load is shifted to the front or side of a pallet or container. Make sure your load is evenly distributed and centered over the forks.

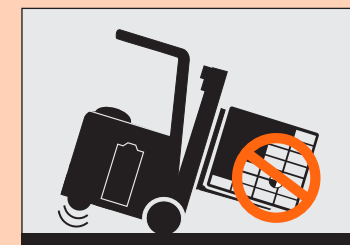

Capacity Plate

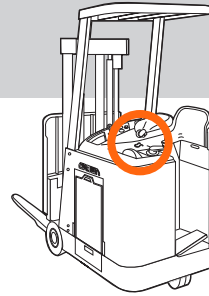

CAPACITY PLATE INFORMATION

The capacity plate is on a console in the operator area. It contains:

- Serial number
- Capacity information (load, load center and lift height)
- Truck type (a fire safety rating)
- Truck weight with battery (does not include load)
- Attachment information (if any)

READING YOUR CAPACITY PLATE

Capacity may be reduced as lift height **A** increases. For example: On the sample plate, 1450kg (3200 lb) can be lifted to 3910mm (154 in.). But above 3910 (154), to 4370 (172), capacity is reduced from 1450 (3200) to 1405 (3100).

Capacity is reduced as load center **B** increases. For example: On the sample plate, 1450kg (3200 lb) can be lifted if the load center is 600mm (24 in.) But if the load center is increased to 830mm (33 in.), capacity is reduced from 1450 (3200) to 1045 (2300).

SAMPLE CAPACITY PLATE

The information shown on this sample plate does not apply to your truck.

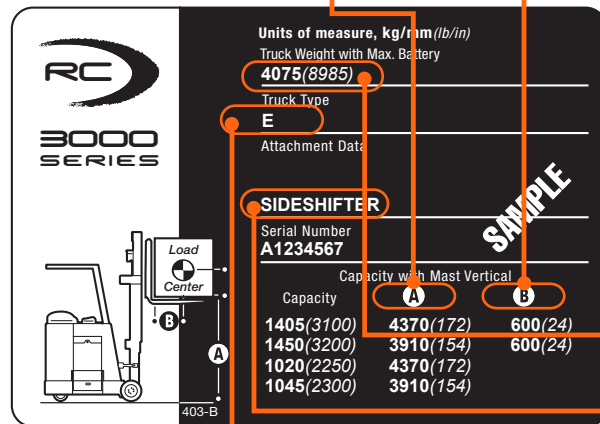

CAUTION

You may not increase capacity if load center is less than shown on your capacity plate.

Note: ANSI B56.1 requires that all data be shown first in Metric units and then USA units.

Know the Hazards

TRUCK WEIGHT

Dockboards, elevators and some floors have limited capacity. Check your capacity plate for the weight of your truck. Make certain you use the correct units of measure. Remember to add the weight of the load you have on the forks.

ATTACHMENT DATA

If an attachment on your truck does not match the information given here on your capacity plate, don't operate your truck. Your capacity plate may be wrong. Report the problem to your supervisor.

TRUCK TYPE

Some truck types are not permitted in areas where there are fire hazards. Watch for marked areas. For example: You must not drive a type E or ES truck in an area restricted to EE or EX trucks.

Power On & Off

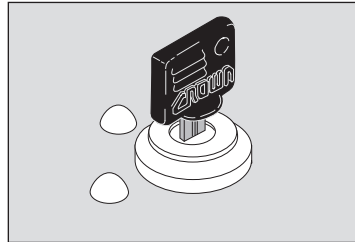
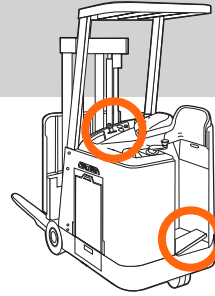

KEY SWITCH

- Turn the key clockwise to the green dot to turn the truck ON.
- When leaving the truck, turn the key back to the red dot to shut the truck OFF.

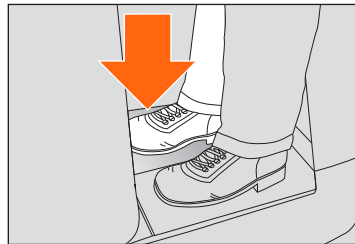

POWER-ON PEDAL

Step down on the right pedal. If the key is turned ON, the steering pump will start running and you can operate the truck.

Note: You must keep the power-on pedal down for power steering to work.

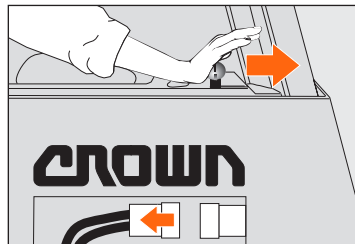

POWER DISCONNECT

Push the Power Disconnect in the direction of the forks to disconnect the battery and cut all power.

Always use the Power Disconnect any time the truck isn't working right. The key switch does not cut all power to the truck.

Don't use the truck if it's not working right. Report the problem to your supervisor.

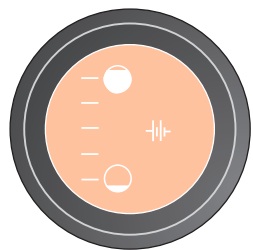

BATTERY CHARGE METER

The lighted bar shows how much charge is left in your battery. A flashing light will warn you that the battery is getting low. Two flashing lights mean you must have the battery changed or recharged.



ENTRY BAR

Keep your feet in the operator area and clear of entry bar. If you put your foot on the entry bar while traveling, the alarm will sound a warning and travel speed is limited to 2.4km/h (1.5 mph). Plugging is reduced. Braking is not affected.

Below 2.4km/h (1.5mph) the alarm will sound a warning but travel speed, plugging and braking are not affected.

! Know the Hazards

! WARNING

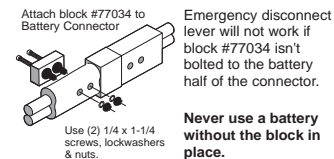

BEFORE CONNECTING THE BATTERY

Make certain the block (Crown #77034) is bolted to the back of the battery half of the connector. Without that block the Power Disconnect won't work. In an emergency you will not be able to cut power to the truck.

Foot Brake

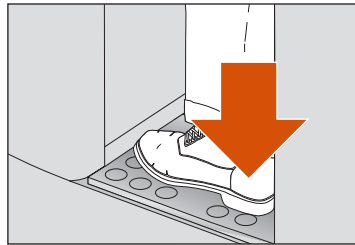

BRAKES OFF

Step all the way down on the left pedal. The brakes are now "off" and you can travel.

Note: Slowing or stopping the truck by plugging (see page 19), requires power to the drive motors. You must have the brake pedal all the way down for plugging to work.

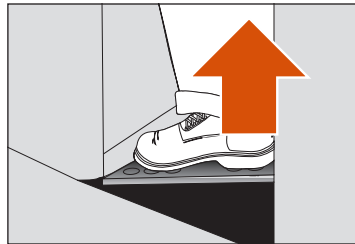

BRAKES ON

Lift your left heel. Let the left pedal rise until you have the desired braking force. Let the pedal come up all the way for full braking.

As the brake pedal starts to lift, power is cut to the drive motors. Remember, without power to the drive motors you can't use plugging.

! Know the Hazards



WATCH YOUR FEET

Keep your feet inside the truck and on the pedals at all times. This truck weighs about 3630kg (8000 pounds) even without a load. You cannot stop or even slow down that much weight with your foot or any part of your body, no matter how slow the truck is moving.

A foot or hand caught between the truck and a wall, post or any fixed object will be crushed or even cut off.

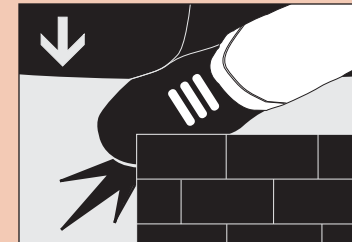

MAKE SURE YOUR BRAKES WORK

Test the brakes on your truck at the start of each shift. Know the distance it takes to stop before you start working.

If at any time the stopping distance is too long for you to stop safely, don't drive the truck. Report any problem to your supervisor.

Traveling & Plugging

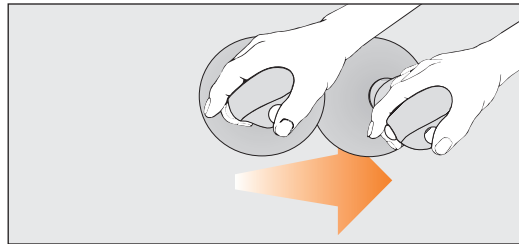
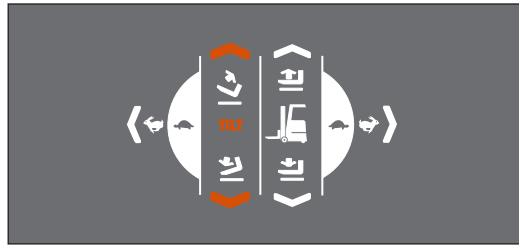
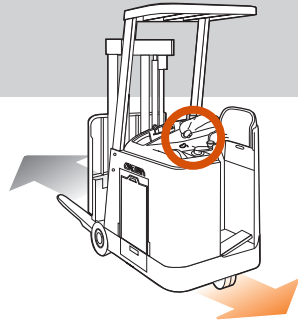

TRAVEL, POWER UNIT FIRST

Pull the multi-function handle toward you to travel in the direction of the power unit (power unit first).

The farther you pull the handle from the neutral position, the faster the truck will travel.

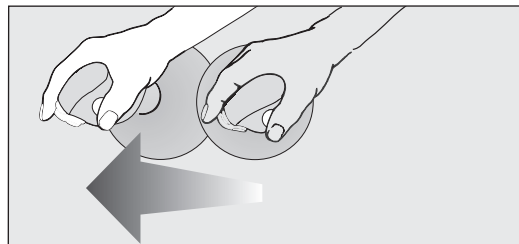

TRAVEL, FORKS FIRST

Push the multi-function handle away from you to travel in the direction of the forks (forks first).

The farther you push the handle from the neutral position, the faster the truck will travel.

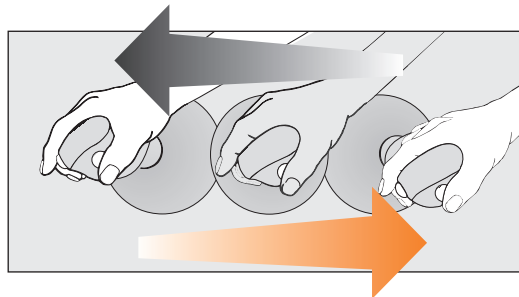

PLUGGING

Plugging is another way to slow down or stop your truck.

While the truck is moving, in either direction, pull or push the multi-function handle through neutral to the opposite direction of travel.

This will not hurt your truck.

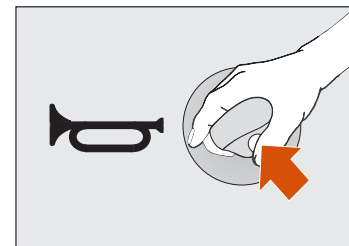
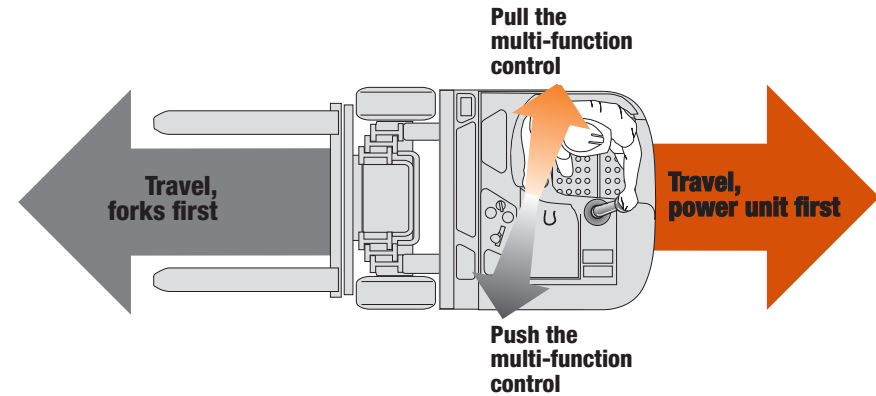

HORN

Press the blue button on the multi-function handle to sound the horn. Use it to warn pedestrians and other drivers.

Use your horn when you come to an intersection or a crosswalk.

! Know the Hazards

PLUGGING VS. BRAKING

Of the two, the foot brake is designed to stop the truck in the shortest distance. Use the foot brake in an emergency, on ramps or in busy areas.

YOU CAN'T HAVE BOTH

Plugging works only when you have the brake pedal all the way down. When the brake pedal begins to lift, power is cut to the drive motor and you will not be able to plug.

Steering & Travel

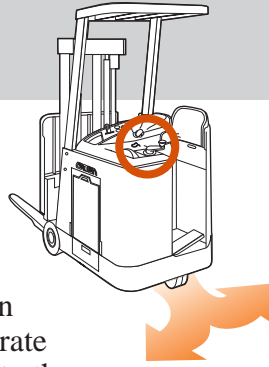

LIFT TRUCKS ARE NOT LIKE AUTOMOBILES

Your lift truck does not steer or drive like an automobile. Be sure you are trained to operate this truck. Drive slowly until you get used to the steering and all other controls.

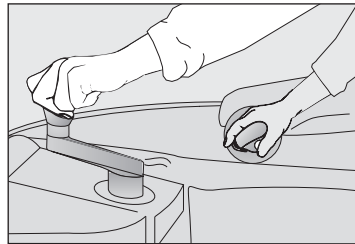

STEERING AND DRIVING

You will need to drive your truck both in the direction of the forks (forks first) and also away from the forks (power unit first or forks trailing). Steering is not the same in both directions. Be careful.



SIMILAR TRUCKS CAN BE DIFFERENT

This style truck can be built with one of two different types of steering. Your company has selected the type which is best for your work area.

Caution: If you ever drive a different truck, even one that looks just like yours, be careful. The steering may be different (see pages 23 and 24).

! Know the Hazards

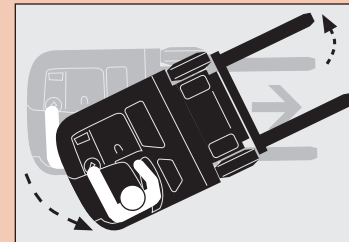

POWER UNIT SWING

Be careful turning while traveling forks first. The power unit will swing wide in the opposite direction. Make sure you have clearance, and watch out for people in the area.



SLOW DOWN FOR SPILLS OR WET FLOORS

Powder or liquid spills can cause slippery floors. Slow down or you could lose control of steering and braking. Be careful and allow for a longer stopping distance.

Don't run over objects on the floor.

Two Types of Steering

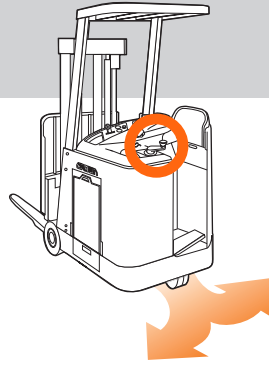

THERE ARE TWO TYPES OF STEERING

This style truck can be built with one of two different types of steering. Your company has selected the type which is best for your work area.

Caution:

- Don't drive if you have not been trained.
- Your truck does not steer like an automobile.
- Drive slowly until you get use to the truck.
- Trucks that look like yours may steer differently.

1 REAR DIRECTIONAL STEERING (Sometimes called Reverse Steering.)
Shows direction truck will turn when steering handle is turned clockwise.

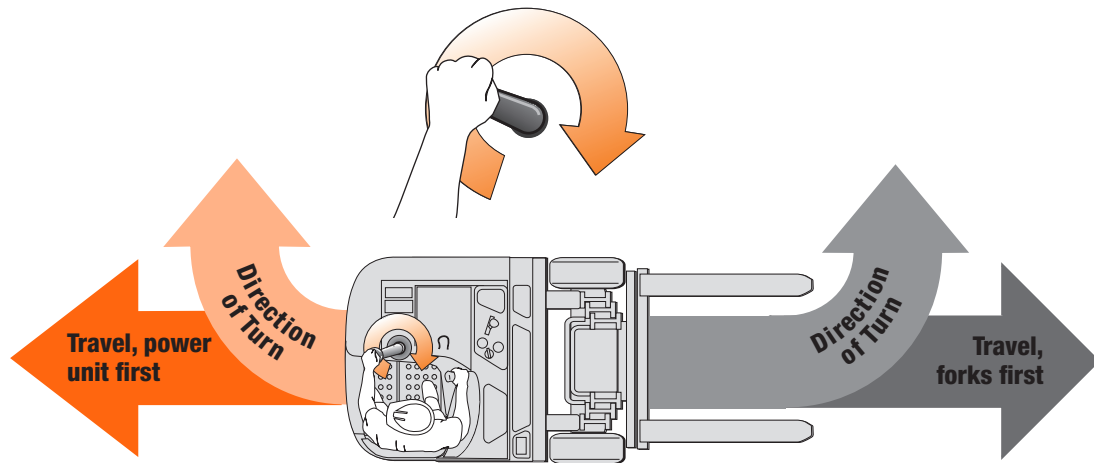

2 FRONT DIRECTIONAL STEERING (Sometimes called Forward Steering.)
Shows direction truck will turn when steering handle is turned clockwise.

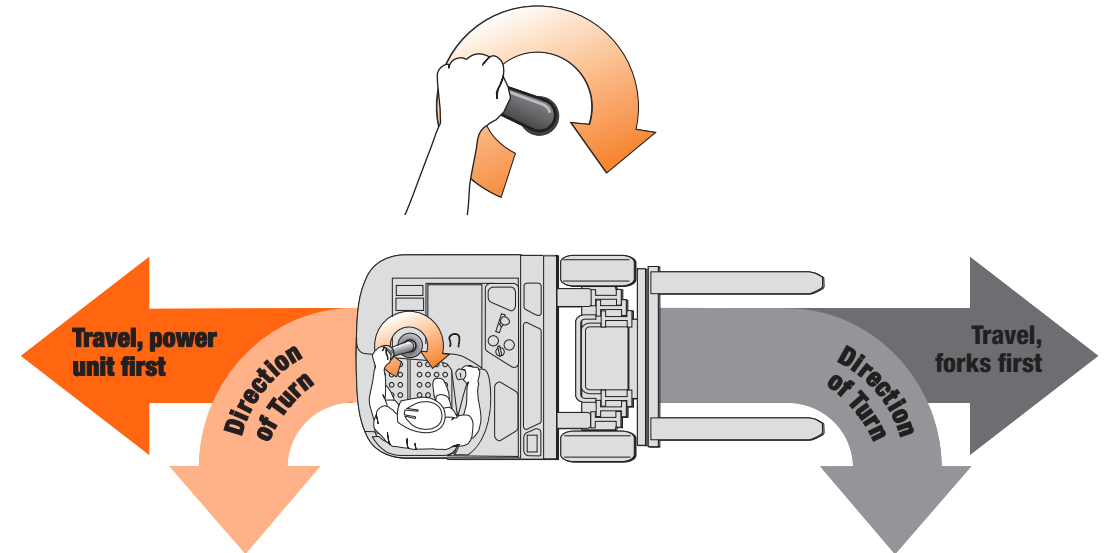

Fork Function

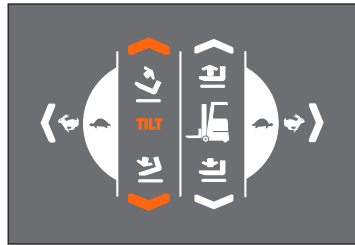
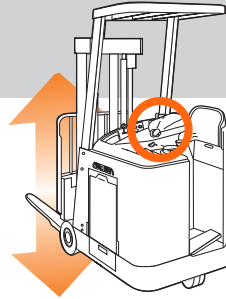

AVAILABLE FORK OR HYDRAULIC FUNCTIONS

Raising and Lowering the forks plus Fork Tilt are standard. You control these two functions with the multi-function handle.

Your truck may also have accessory functions like Sideshift, Carton Clamp or Push-Pull. You control these functions with the accessory control levers.

Use these hydraulic functions when you move, put away or take down loads.

RAISE/LOWER

You are always in the Raise/Lower function unless you select the Fork Tilt function.

SELECTING FORK TILT

Press the orange button on the multi-function handle to select Fork Tilt.

Note:

- You are always in the Raise/Lower function when you turn the truck on.
- You must have the handle in neutral to select Tilt.
- You must hold the orange button in until you move the handle from neutral and the forks and mast start to tilt.

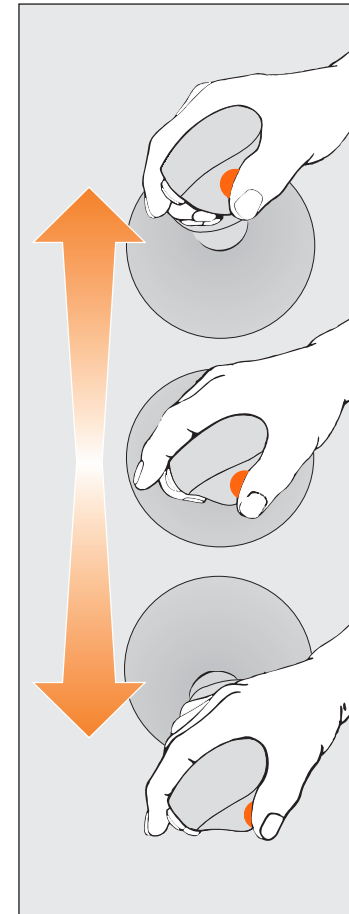
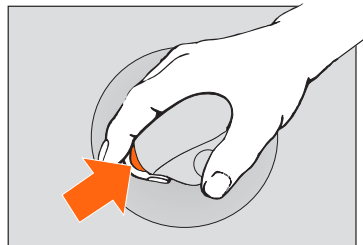

LIFT UP MULTI-FUNCTION

Select a function and lift the multi-function handle up.

The forks will raise or the forks will tilt up (mast will tilt back), depending on which function you selected.

The further you lift the handle up, the faster the movement will be.

NEUTRAL

You must have the control in neutral to select the Tilt function. Hold the orange button in until you move the control and the mast starts to tilt.

Return the handle to neutral and you will be back in the Raise/Lower function.

PUSH DOWN MULTI-FUNCTION

Select a function and push the multi-function handle down.

The forks will lower or the forks will tilt down (mast will tilt forward), depending on which function you selected.

The further you push the handle down, the faster the movement will be.

Retractable Guard optional

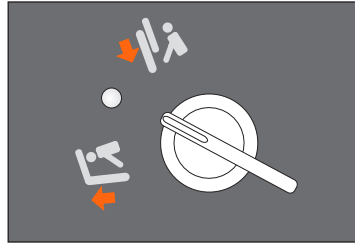
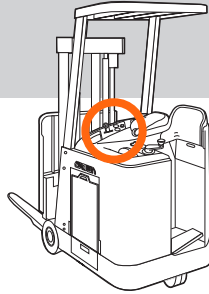

RETRACTABLE OVERHEAD GUARD

Turn the knob clockwise to lower the guard about 150mm (5.9 in.). Turn the knob counterclockwise to raise the guard.

Lower the guard if you must work in areas with low overhead clearance. Always raise the guard for overhead protection whenever you leave a low clearance area.

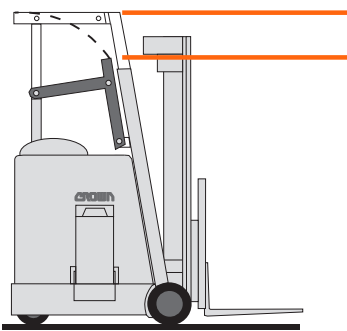

2300mm (90.5 in.) raised height

2150mm (84.6 in.) lowered height

OPERATING LIMITS

- You cannot lower the guard if you have the forks raised above operator compartment height.
- You cannot raise the forks above operator compartment height if you have the guard lowered.

! Know the Hazards

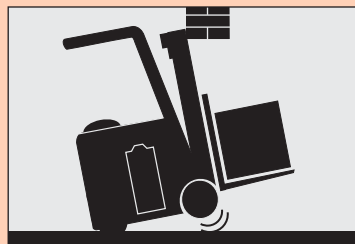

CHECK OVERHEAD CLEARANCE

Know the height of your truck and when you must lower the guard to clear low obstructions.

PROTECT YOURSELF

Falling objects can cause injury. Always raise the retractable guard when you leave a low clearance area.

WATCH YOUR HEAD WHEN THE GUARD IS DOWN

Look where you're going and check for objects that could intrude or poke into the operator area.

Hydraulic Accessories

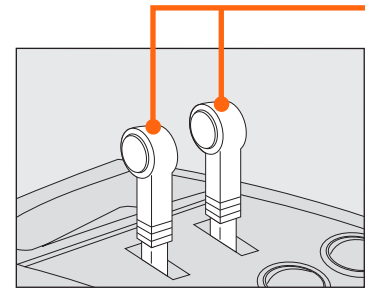

Hydraulic accessory levers (optional)

HYDRAULIC ACCESSORY OPERATION

Pull the lever toward you and you'll get the action shown by the symbol in the top of the knob. Push the lever away from you and you'll get the opposite action.

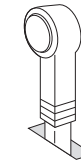

For example: If you have a Sideshift accessory, pull the lever toward you to shift the forks to the right, or push the lever away from you to shift the forks to the left.

Daily Safety Check

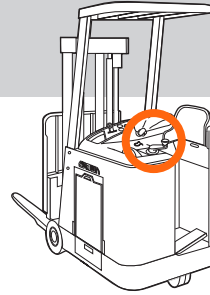

CHECK YOUR TRUCK BEFORE STARTING WORK

You must make sure your truck is safe to use.

1. Walk around your truck and check it over.

- Check to make sure the battery is charged, water level is OK and vent caps are in place. Don't use an open flame to check the battery.
- Make certain the battery retainers on both sides of the truck are properly installed.
- See that all wheels are in good condition.
- Check that both forks are secure and not bent, cracked or badly worn.
- Inspect lift chains for damage.
- See that the load backrest and overhead guard are in place and fastened.
- Look under the truck for signs of hydraulic leaks.
- Test the horn.
- Make sure the power disconnect works.

2. Test drive your truck in an uncongested area.

- Try all the hydraulic functions.
- Check that the steering is easy and smooth.
- Drive the truck slowly in both directions.
- Drive through the full speed range in both forward and reverse.
- Check braking and plugging distances in forward and reverse. Load size and floor conditions can affect these distances.
- Know the distance it takes to stop before you start working. If the braking distance is too long to stop safely, don't drive the truck.

If anything doesn't look or feel right, don't drive the truck. Report the problem to your supervisor.

You can get checklist forms from your Crown dealer (part no. OF-3772). Used properly, this checklist can alert service people to needed repairs.

Be a Safe Driver

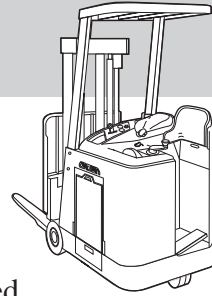

The most important component is you.

MAKE SURE YOU ARE READY TO DRIVE

- Do not use this truck unless you are trained and certified.
- Be certain you understand how your truck works and the hazards that go with it. Don't drive the truck if you have any doubts.
- Know the capacity of your truck (Load Weight, Load Center and Lift Height). Make certain you use the correct units of measure.
- Some trucks are not allowed in areas where there are fire hazards. Be certain your truck is the correct fire safety type for the area.
- Make sure your hands and shoes are clean and dry, and your clothing is proper for the job.

MAKE SURE YOUR TRUCK IS READY

- Inspect your truck before using it (see pages 29 and 30). If it's not working right, or something is broken, report the problem to your supervisor. Don't use the truck.
- In an open area, test the brakes and plugging. Check at a slow travel speed first, then a faster one. Know the distance it takes to stop before you start work.



DRIVE CAUTIOUSLY, BE ALERT

- Never stick a foot or any part of your body outside the operator area, no matter how slow the truck is moving. You cannot stop 3630 kg (8000 pounds) with any part of your body. A foot or hand caught between the truck and a fixed object will be crushed or even cut off.
- Keep your hands on the controls and your feet on the pedals.
- Travel in the direction that gives you the best view. Look where you are going and slow down in congested areas.
- Slow down for wet or slippery floors. Don't run over things.
- Travel with the forks close to the ground, retracted and tilted up. Place the load against the load backrest (vertical face of the forks).
- Look where you are going before you change direction of travel.
- See that you have room to drive and turn. Always check for overhead objects. Watch out for power unit swing.
- Slow down when making turns.
- Avoid sudden movement of controls. Learn to use them smoothly at a moderate, even rate.
- Check clearances before raising or lowering the forks or load.
- Be extra careful if you must use your truck in an area where there is a risk of falling objects. Don't operate your truck with the retractable overhead guard lowered.

Continued next page...

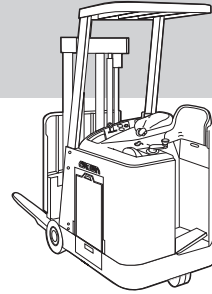

WATCH OUT FOR OTHER PEOPLE

- Slow down. Yield or stop for pedestrians. Use your horn when you come to a crosswalk or intersection.
- Be careful that you don't pin or crush someone. *For example: Never drive your truck toward anyone standing in front of a fixed object.*
- Never allow passengers on your truck.
- Watch out for power unit swing.
- Keep others away from your truck while you're working. Don't ever allow anyone on or under the load or forks.
- Don't let anyone use your truck unless they are trained and certified.
- Never lift anyone with the forks unless they are using an approved platform. Even then use extreme caution:
 - Use a securely attached and approved safety platform.
 - Make certain lifting mechanism is operating properly.
 - Have load backrest vertical (never tilt when elevated).
 - Make certain truck is in neutral and brake is applied.
 - Lift and lower slowly.
 - Watch for overhead obstructions.
 - Be sure you can see and hear the person being lifted.
- Never transport anyone on the platform from one location to another.

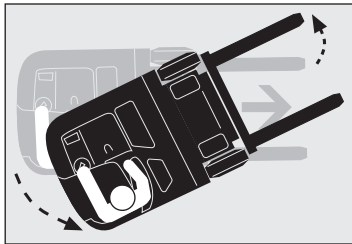

AVOID FALLS AND TIPOVERS

- Stay away from the edge of docks and ramps.
- Check that bridgeplates and dockboards are secure. Be certain that either the trailer wheels are chocked or the trailer is locked to the dock. Check capacities. Be sure your truck, with load, isn't too heavy for where you are driving.
- Make sure the load you are moving is stable. Spread the forks as far as you can and center the load. Insert the forks as far under the load as you can. Be even more careful with long, high or wide loads. They can be less stable.
- Use forward tilt only when you have the load over a stack or close to the floor. Use minimum fork tilt to pick up or place a load. When lifting or lowering outside a rack, keep the load backrest vertical or tilted back slightly.
- When moving loads on grades or ramps, drive with your forks pointed upgrade. Without a load, drive with forks downgrade. Slow down, and don't turn on grades or ramps.

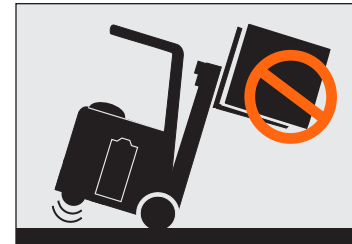

LEAVING YOUR TRUCK

- Stop your truck completely before getting off.
- Lower the forks to the floor. Turn the truck off or disconnect the battery.
- Avoid parking on inclines. But if you must, block the wheels of your truck.

Battery Maintenance

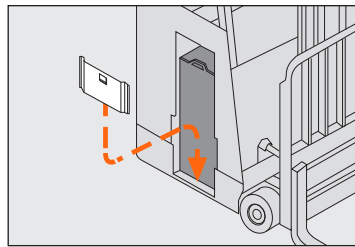
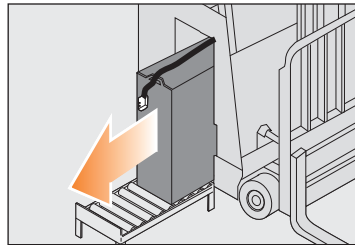
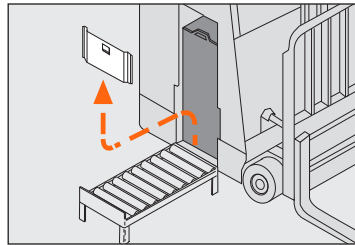
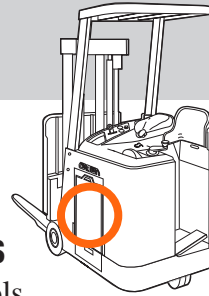

WHEN YOU INSTALL OR CHANGE BATTERIES

- Turn the truck OFF. Check that all controls are in neutral.
- Make certain you use the correct size and weight battery. Never operate a truck that has an underweight or undersize battery installed.
- Use a roller stand to install or remove a battery. Make sure the roller stand is the same height as the rollers in the truck's battery compartment. Also make sure the roller stand is at least as long as your battery.
- Never let anything metal touch the top of the cells. You could cause sparks or do damage to the battery. Use an insulator (such as plywood) when necessary.
- Use an approved spreader bar to place a battery on, or remove it from a stand. Make sure you adjust the spreader bar hooks to fit the battery.

AFTER INSTALLING YOUR BATTERY

- Replace the battery retainer. Make certain the retainers on both sides of the truck are in place.
- Be sure the block #77034 is bolted to the back of the battery half of the connector.
- Connect the battery. Turn the truck ON and check truck operation.

! Know the Hazards

! DANGER



Batteries produce explosive gas. Do not smoke, use open flame, or create an arc or sparks near this battery. Ventilate well in enclosed areas and when charging.

Batteries contain **Sulfuric Acid** which causes severe burns. Do not get in eyes, on skin, or clothing. In case of contact, flush immediately. Get medical attention if your eyes are affected.

TRUCK BATTERIES CAN BE DANGEROUS

Your truck battery produces fumes that can explode. It also contains acid that could burn or disfigure you.

- Do not try to install, remove, charge or service your truck battery unless you are trained and authorized.
- Never smoke or use an open flame around batteries.
- Your company should provide an area where it is safe to work on batteries. Use that area for all battery work.
- Use protective equipment such as gloves, eye shields, aprons etc.

! WARNING

Minimum battery size allowed
XXX mm (XX.XX in.) wide
XXX mm (XX.XX in.) long

Undersize battery can affect truck handling and stability. You could have an accident.

Use U.L. classified Type EO battery.

BATTERY SIZE

Make certain you use the correct size and weight battery. Never operate a truck that has an underweight or undersized battery installed.

Continued next page...

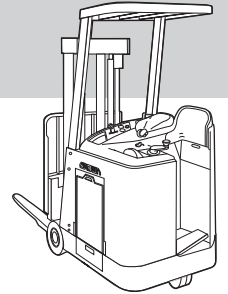

EACH WARNING LABEL ON YOUR TRUCK IS IMPORTANT

Read and obey all of them to protect yourself and others.



Know the Hazards

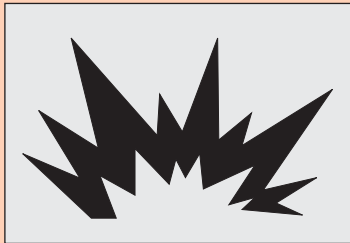

BEFORE CHARGING YOUR TRUCK BATTERY

- Charge the battery only in areas designated for that use.
- See that the battery cells are filled to the proper level. Never use an open flame to check the battery.
- Make certain the charger is the same voltage and amperage as your battery.
- Read the battery charger instructions.
- Be sure the charger is turned OFF before connecting the battery to the charger. Otherwise you might create a spark which could cause the battery to explode.

WARNING

Attach block #77034 to Battery Connector

Emergency disconnect lever will not work if block #77034 isn't bolted to the battery half of the connector.

Use (2) 1/4 x 1-1/4 screws, lockwashers & nuts.

Never use a battery without the block in place.

BEFORE CONNECTING YOUR BATTERY

Make certain the block (Crown #77034) is bolted to the back of the battery half of the connector. Without that block the Power Disconnect won't work. In an emergency you will not be able to cut power to the truck.

Make sure the truck key switch is turned off and all controls are in the off position.